

- Up to 8 PON ports, 1U case
- Hot-swappable redundant power modules
- Remote management via CLI, SNMP
- Compliance with G.988, G.984.x and TR-156 standards
- Cable TV with data transmission
- Optimal solution for a small village or an apartment building



LTP-4X rev.C/rev.D



LTP-8X rev.C/rev.D

Optical Line Terminal (OLT) is designed to provide broadband access over Passive Optical Network (PON).

GPON interfaces are used to connect the passive optical network (PON). Up to 128 subscriber optical terminals can be connected to each interface via a single fiber. The access to the operator transport network is provided via 10 Gigabit or combined Gigabit uplink interfaces.

OLT LTP allows operators building scalable, last mile fault tolerant networks to ensure the highest safety standards. OLT manages subscriber devices, traffic switching and connection to the transport network.

Broadband subscriber access using FTTH technology is the highest quality version of the Triple Play service delivery, as it provides high data rates over long distances.

The main advantage of PON technology is the lack of electrically powered active nodes within the section from OLT to ONT, which greatly reduces the network operating cost. Furthermore, PON technology saves on cabling infrastructure by reducing the total length of the optical fiber, as only one fiber for a group of up to 128 subscribers is used within the section from the central node to the splitter.

OLT LTP rev.C/rev.D support two hot-swappable power modules with the ability of automatic transfer to a redundant module.

OLT GPON interfaces

Name	Number of PON ports	Number of Uplink ports	Maximum number of ONT
OLT LTP-4X	4	4 × Combo 10/100/1000BASE-T/ 1000BASE-X 2 × 10GBASE-X (SFP+)/1000BASE-X	512
OLT LTP-8X	8	4 × 10/100/1000BASE-T 4 × Combo 10/100/1000BASE-T/ 1000BASE-X 2 × 10GBASE-X (SFP+)/1000BASE-X	1024

Features and capabilities

Interfaces

LTP-4X

Uplink

- 2 ports of 10GBASE-X (SFP+)/1000BASE-X
- 4 Combo ports of 10/100/1000BASE-T/1000BASE-X (SFP)

Downlink

- 4 ports of 2.5/1.25 Gbps GPON (SFP)

LTP-8X

Uplink

- 2 ports of 10GBASE-X (SFP+)/1000BASE-X
- 4 Combo ports of 10/100/1000BASE-T/1000BASE-X (SFP)
- 4 ports of 10/100/1000BASE-T

Downlink

- 8 ports of 2.5/1.25 Gbps GPON (SFP)

Port modes

- Duplex/half-duplex mode
10/100/1000 Mbps mode for electric ports
- Duplex 1/10 Gbps mode for optic ports

SFP PON parameters¹

- Medium — single-mode optical fiber — 9/125, G.652
- Splitting ratio — up to 1:128
- RSSI (Received Signal Strength Indication)
- DDM (parameters output in CLI):
 - Digital RSSI
 - Module Temperature
 - Supply Voltage
 - Laser Bias Current
 - Tx Optical Power Output

Class B+

- Compliance with ITU-T G.984.2, FSAN Class B+, SFF-8472 standards
- Maximum transmission distance: 20 km
- Transmitter: 1490 nm DFB Laser
 - Data rate: 2488 Mbps
 - Average output power: +1.5..+5 dBm
 - Spectral linewidth: -20 dB 1.0 nm
- Receiver: 1310 nm APD/TIA
 - Data rate: 1244 Mbps
 - Receiver sensitivity: -28 dBm
 - Receiver optical overload: -8 dBm

Class C++

- Compliance with ITU-T G.984.2, FSAN Class C++, SFF-8472 standards
- Maximum transmission distance: 40 km
- Transmitter: 1490 nm DFB Laser
 - Data rate: 2488 Mbps
 - Average output power: +7..+10 dBm
 - Spectral linewidth: -20 dB 1.0 nm
- Receiver: 1310 nm APD/TIA
 - Data rate: 1244 Mbps
 - Receiver sensitivity: -32 dBm
 - Receiver optical overload: -12 dBm
 - Burst-mode receiver dynamic range: 20 dB

Switch

- Bandwidth — 128 Gbps
- MAC table — 16K entries
- Support for up to 4K VLANs in compliance with 802.1Q
- Quality of Service (QoS)

Physical parameters

- Power supply¹:
 - 150–250 V AC, 50–60 Hz
 - 36–72 V DC
- Power consumption:
 - LTP-4X rev.C/rev.D: no more than 50 W
 - LTP-8X rev.C/rev.D: no more than 55 W
- Operating temperature: from -5 to +40 °C
- Relative humidity: up to 80 %
- Dimensions (W × H × D) with installed power module: 430 × 44 × 317 mm, 19", 1U case

Standards

- ITU-T G.988 GPON
- ITU-T G.984x GPON
- ITU-T G.8032/Y.1344 Ethernet nng protection switching
- IEEE 802.3i 10BASE-T Ethernet
- IEEE 802.3u 100BASE-T Fast Ethernet
- IEEE 802.3ab 1000BASE-T Gigabit Ethernet
- IEEE 802.3z Fiber Gigabit Ethernet
- ANSI/IEEE 802.3 NWay auto-negotiation
- IEEE 802.3x Full Duplex and flow control
- IEEE 802.3ad Link aggregation
- IEEE 802.1p Protocol for Traffic Prioritization
- IEEE 802.1Q Virtual LANs
- IEEE 802.1ad Provider Bridges (QinQ)
- IEEE 802.1v VLAN Classification by Protocol and Port
- IEEE 802.3ac VLAN tagging
- IEEE 802.1d MAC bridges
- IEEE 802.1w Rapid Reconfiguration of Spanning Tree
- IEEE 802.1s Multiple Spanning Trees

¹ The parameter is defined when ordering.

Features and capabilities (continued)

Additional features

- Port mirroring, VLAN mirroring
- MAC table: 16K per switch, 4K per port
- MAC address limiting
- STP, RSTP, MSTP
- ERPSv2
- QoS: 802.1p, DSCP, WRR
- Port isolation, port isolation within a VLAN
- Unicast/multicast/broadcast traffic restrictions
- ACL IPv4
- QinQ with compliance to IEEE 802.1ad
- Up to 1024 multicast groups
- IGMP/MLD Fast Leave
- IGMP/MLD Proxy
- IGMP/MLD Snooping
- IGMP/MLD Querier
- DHCPv4 Snooping
- IP Source guard
- DHCPv4/DHCPv6 Relay Agent (opt.82, ip-helper)
- PPPoE Intermediate agent
- LLDP (802.1ab)
- Storm Control
- Policy
- Utilization by ONT services
- GPON port redundancy
- PoE management on ONT ports

Management and monitoring

- RADIUS, TACACS+
- Management and monitoring via CLI, SNMP
- Access restriction: by password, by IP address, by privilege level
- Support for several management interfaces

Centralized management system

The centralized management system Eltex.EMS for ELTEX equipment provides the following features:

- searching, adding, configuring, state monitoring of OLT/ONT and other network elements
- monitoring of main parameters and power supply
- monitoring of physical and logical interfaces statistics
- subscriber ports management: configurations, profiles
- management of mass automatic firmware update system for subscriber PON devices
- online dynamic graph drawing of various static parameters
- graphic displaying of physical ports state
- launch of main configuration tools: SSH, Telnet

Statistics:

- centralized collecting, storing and processing the operation, event and alarm logs
- collecting and storing alarm messages
- quick search system for subscriber devices
- information on number of active subscribers in a PON network
- state monitoring and statistics by Internet, VoIP, IPTV and CaTV services
- statistics of PON subscribers activity
- centralized collection of device messages via Syslog
- logging all users actions in the system

Use case

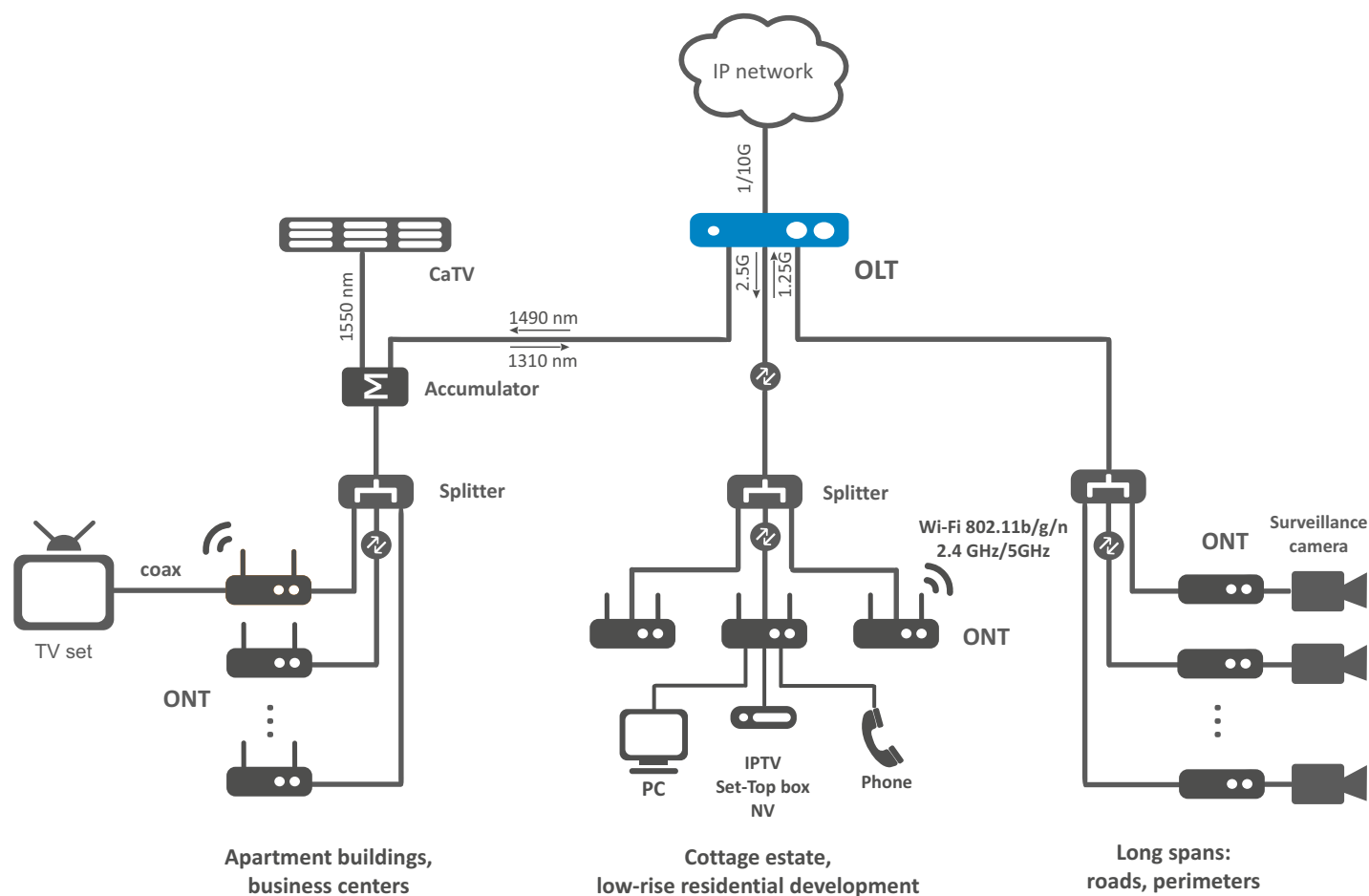

Ordering information

Name	Description
OLT LTP-4X rev.C/rev.D	OLT LTP-4X, 4 ports of SFP-xPON, 4 Combo ports of 10/100/1000BASE-T/1000BASE-X, 2 ports of 10GBASE-X (SFP+)/1000BASE-X, embedded switch L2+, RSSI
OLT LTP-8X rev.C/rev.D	OLT LTP-8X, 8 ports of SFP-xPON, 4 ports of 10/100/1000BASE-T, 4 Combo ports of 10/100/1000BASE-T/1000BASE-X, 2 ports of 10GBASE-X (SFP+)/1000BASE-X, embedded switch L2+, RSSI
Power modules	
PM160-220/12	Power module PM160-220/12, 220 V AC, 160 W
PM100-48/12	Power module PM100-48/12, 48 V DC, 100 W
Related software	
EMS-OLT	EMS-OLT option of Eltex.EMS for management and monitoring of ELTEX network elements: 1 OLT

Contact us

+7 (383) 274 10 01
+7 (383) 274 48 48

eltex@eltex-co.ru

www.eltex-co.com

About ELTEX

ELTEX Enterprise is a leading Russian developer and manufacturer of communication equipment with 30 years of history. Complete solutions and their seamless integrability into the Customer's infrastructure are the priority growth areas of the company.