

- Bandwidth up to 176 Gbps
- Non-blocking architecture
- L3 switches
- 4 ports of 10G
- Stacking up to 8 devices
- Multicast support (IGMP Snooping, MVR)
- Advanced security functions (L2-L4 ACL, IP Source Guard, Dynamic ARP Inspection, etc.)
- Uninterrupted power from battery



The new generation of access switches MES2300B-48 connects end users to the network of large enterprises, small and medium businesses and telecommunications operator networks using 1G/10G.

The switch functionality provides physical stacking, support for VLANs, multicast groups and advanced security features.

The MES2300B-48 switch has the ability to connect a rechargeable battery supply to ensure guaranteed power supply in case of 230 V primary power network failure. The switch is equipped with a power module that allows charging the battery when 230 V is available. The backup power system makes it possible to monitor the state of the primary network and notify of a power type switching.

Technical features

Interfaces	
10/100/1000BASE-T (RJ-45)	48
10GBASE-R (SFP+)/1000BASE-X (SFP)	4
Console port RS-232 (RJ-45)	1
Bandwidth	
Bandwidth	176 Gbps
Throughput for 64 bytes ¹	130.95 MPPS
Buffer memory	3 MB
RAM (DDR4)	2 GB
ROM (RAW NAND)	512 MB
MAC table	16384
ARP table ²	2039
VLAN table	4094
L2 Multicast groups	2048
SQinQ rules	1320 (ingress), 1320 (egress)
MAC ACL rules	1976
IPv4/IPv6 ACL rules	1975/988
L3 IPv4 Unicast routes ³	4066
L3 IPv6 Unicast routes ³	1015
L3 IPv4 Multicast (IGMP Proxy, PIM) routes ³	2029
L3 IPv6 Multicast (IGMP Proxy, PIM) routes ³	505
VRRP routers	255
Maximum size of ECMP groups	8

¹ Values are given for one-way transmission.

² For each host in the ARP table, an additional entry is created in the switching table.

³ IPv4/IPv6 Unicast/Multicast routes use shared hardware resources.

Technical features (continued)

Performance

VRF number	16 (including default VRF)
L3 interfaces	2032
Link Aggregation Groups (LAG)	32, up to 8 ports in one LAG
Quality of Service (QoS)	8 egress queues per port
Jumbo frames	10240 bytes
Stacking	8 devices

Features and capabilities

Interface features

- Head-of-line blocking (HOL) protection
- Back Pressure
- Auto MDI/MDIX
- Jumbo Frames
- Flow Control (IEEE 802.3X)
- Port Mirroring (SPAN, RSPAN)
- Stacking

MAC address functions

- Independent learning mode per VLAN
- MAC Multicast Support
- Configurable aging time of MAC addresses
- Static MAC Entries
- MAC Flapping

VLAN support

- Voice VLAN
- 802.1Q
- Q-in-Q
- Selective Q-in-Q
- GVRP

L2 Multicast functions

- Multicast profiles
- Static Multicast groups
- IGMP Snooping v1,2,3
- Host/port-based IGMP Snooping Fast Leave
- IGMP proxy-report
- IGMP authorization through RADIUS
- MLD Snooping v1,2
- IGMP Querier
- MVR

L2 functions

- STP (Spanning Tree Protocol, IEEE 802.1d)
- RSTP (Rapid Spanning Tree Protocol, IEEE 802.1w)
- MSTP (Multiple Spanning Tree Protocol, IEEE802.1s)
- PVSTP+
- RPVSTP+
- Spanning Tree Fast Link option
- STP Root Guard
- BPDU Filtering
- STP BPDU Guard
- Loopback Detection (LBD)
- ERPS (G.8032v2)
- Private VLAN
- Layer 2 Protocol Tunneling (L2PT)

L3 functions

- IP routes
- RIPv2, OSPFv2, OSPFv3, IS-IS (IPv4 Unicast), BGP¹ (IPv4 Unicast, IPv4 Multicast)
- BFD protocol (for BGP)
- Address Resolution Protocol (ARP)
- Proxy ARP
- VRRP
- Multicast dynamic routing protocols PIM SM, PIM DM, IGMP Proxy
- ECMP Load Balancing
- IP Unnumbered
- VRF lite

Link Aggregation functions

- LAG group creation
- LACP
- LAG Balancing Algorithm
- Multi-Switch Link Aggregation Group (MLAG)

IPv6 support

- IPv6 Host
- Dual-stack IPv4, IPv6

Service functions

- Optical transceiver diagnostics
- Green Ethernet

Security functions

- Protection against unauthorized DHCP servers (DHCP Snooping)
- DHCP option 82
- IP Source Guard
- Dynamic ARP Inspection
- sFlow
- MAC-based authentication, Port Security, Static MAC entries
- Port-based authentication IEEE 802.1x
- Guest VLAN
- DoS attack prevention
- Traffic segmentation
- DHCP clients filtering
- BPDU attack prevention
- NetBIOS/NetBEUI filtering

Quality of Service (QoS) and traffic limit

- QoS statistics
- Shaping, policing
- IEEE 802.1p Class of Service
- Storm Control for different traffics (broadcast, multicast, unknown unicast)

¹ BGP protocol support is provided under license.

Features and capabilities (continued)

- Bandwidth management
- Strict priority/Weighted Round Robin (WRR) scheduling algorithms
- Three marking colors
- ACL-based traffic classification
- ACL-based CoS/DSCP metric assignment
- Setting the IEEE 802.1p priority for management VLAN
- DSCP to CoS, CoS to DSCP remarking
- ACL-based VLAN assignment
- 802.1p DSCP metric assignment for IGMP

OAM

- 802.3ah Ethernet Link OAM
- 802.3ah Unidirectional Link Detection

Access Control Lists (ACL)

- L2-L3-L4 ACL (Access Control List)
- Time-Based ACL
- IPv6 ACL
- ACL based on:
 - Switch port
 - 802.1p priority
 - VLAN ID
 - EtherType
 - DSCP
 - Protocol type
 - TCP/UDP port number
 - User Defined Bytes

Management functions

- Upload/download of configuration file and firmware via TFTP
- SNMP (Simple Network Management Protocol)
- CLI (Command Line Interface)
- Web interface
- Syslog
- NTP (Simple Network Time Protocol)
- Traceroute
- LLDP (802.1ab) + LLDP MED
- LLDP (IEEE 802.1ab)
- Switch access control — Privilege levels for users
- Management ACL
- Management interface blocking
- Local authentication
- IP addresses filtering for SNMP
- RADIUS, TACACS+ (Terminal Access Controller Access Control System) clients
- SSH, Telnet server
- SSH, Telnet client
- SSL
- Macrocommands support
- CLI commands logging
- System log
- DHCP autoprovision
- DHCP Relay (Option 82)
- DHCP Option 12
- Debugging commands
- Rate limit of traffic to CPU
- Password encryption
- Password recovery
- Ping (IPv4/IPv6)

Monitoring functions

- Interface statistics
- RMON/SMON remote monitoring
- IP SLA
- CPU utilization monitoring per task and traffic type
- Temperature monitoring
- TCAM monitoring

Uninterrupted power supply

- Automatic switch to the battery (12 V) when the primary network (230 V) is disconnected
- Charging the battery (12 V) from the primary network (230 V) during operation
- Power type monitoring (SNMP)
- Notification when switching the power type
- Indication of battery connection
- Low battery charge level signaling
- Short circuit protection

MIB/IETF

- RFC 1065, 1066, 1155, 1156, 2578 MIB Structure
- RFC 1212 Concise MIB Definitions
- RFC 1213 MIB II
- RFC 1215 MIB Traps Convention
- RFC 1493, 4188 Bridge MIB
- RFC 1157, 2571-2576 SNMP MIB
- RFC 1901-1908, 3418, 3636, 1442, 2578 SNMPv2 MIB
- RFC 1271, 1757, 2819 RMON MIB
- RFC 2465 IPv6 MIB
- RFC 2466 ICMPv6 MIB
- RFC 2737 Entity MIB
- RFC 4293 IPv6 SNMP Mgmt Interface MIB
- Private MIB
- RFC 3289 DIFFSERV MIB
- RFC 2021 RMONv2 MIB
- RFC 1398, 1643, 1650, 2358, 2665, 3635 Ether-like MIB
- RFC 2668 802.3 MAU MIB
- RFC 2674, 4363 802.1p MIB
- RFC 2233, 2863 IF MIB
- RFC 2618 RADIUS Authentication Client MIB
- RFC 4022 MIB for TCP
- RFC 4113 MIB for UDP
- RFC 2620 RADIUS Accounting Client MIB
- RFC 2925 Ping & Traceroute MIB
- RFC 768 UDP
- RFC 791 IP
- RFC 792 ICMPv4
- RFC 2463, 4443 ICMPv6
- RFC 4884 Extended ICMP to support Multi-Part Messages
- RFC 793 TCP
- RFC 2474, 3260 Definition of the DS field in the IPv4 and IPv6
- RFC 1321, 2284, 2865, 3580, 3748 Extensible Authentication Protocol (EAP)
- RFC 2571, RFC2572, RFC2573, RFC2574 SNMP
- RFC 826 ARP
- RFC 854 Telnet

Use case

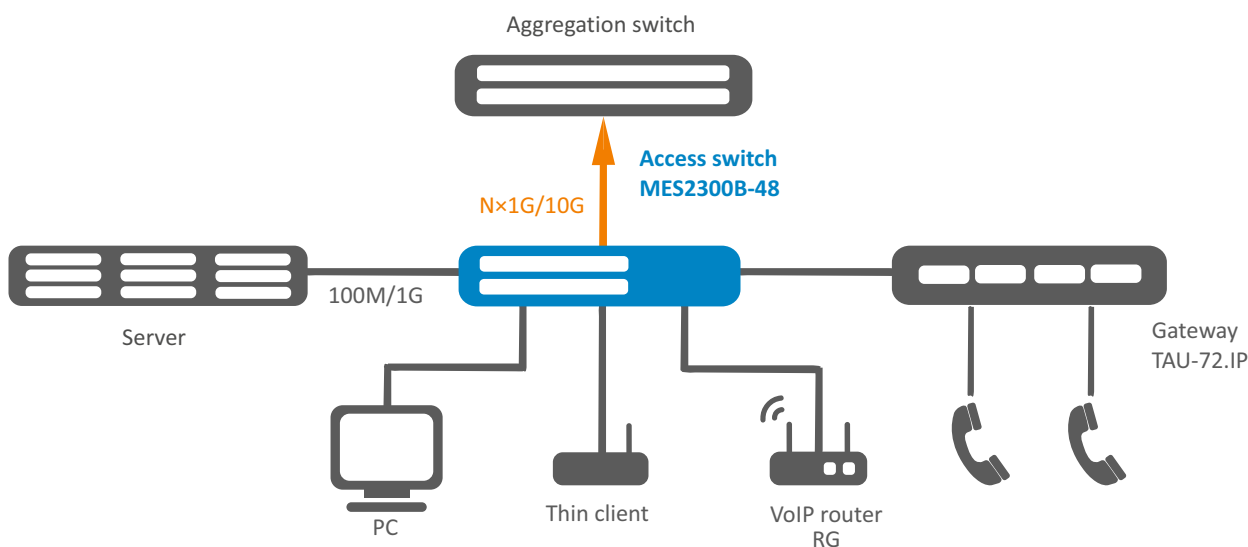

Physical parameters

Physical parameters and environmental features

Power supply	100–240 V AC, 50–60 Hz; 12 V DC
Input current	including battery: 0.3–0.9 A excluding battery: 0.2–0.6 A
Maximum power consumption	55 W
Maximum power consumption excluding battery charge	40 W
Heat dissipation	43 W
Dying Gasp support	yes
Operating temperature	from -20 to +50 °C
Storage temperature	from -50 to +70 °C
Operating humidity	no more than 80 %
Cooling	2 fans
Form factor	19", 1U
Dimensions (W × H × D)	440 × 44 × 280 mm
Weight	4.1 kg

Ordering information

Name	Description
MES2300B-48 AC	MES2300B-48 Ethernet switch, 48 × 10/100/1000BASE-T, 4 × 10GBASE-R (SFP+)/1000BASE-X (SFP), L3, 100–240 V AC, 12 V DC

Related software

ECCM-MES2300B-48 AC	ECCM-MES2300B-48 option of Eltex ECCM management system for Eltex network elements management and monitoring: 1 network element MES2300B-48 AC
---------------------	--

Contact us

+7 (383) 274 10 01
+7 (383) 274 48 48

eltex@eltex-co.ru

www.eltex-co.com

About ELTEX

ELTEX Enterprise is a leading Russian developer and manufacturer of communication equipment with 30 years of history. Complete solutions and their seamless integrability into the Customer's infrastructure are the priority growth areas of the company.