

- Throughput capacity 176 Gbps
- Non-blocking switching fabric
- L3 functions
- Stacking support
- Multicast support (IGMP Snooping, MVR)
- Advanced security functions (L2-L4 ACL, IP Source Guard, Dynamic ARP Inspection, etc.)

New generation of access switches provides end users connection to large-scale corporate networks, small and medium business networks and to service provider networks using 1G/10G interfaces.

MES2324FB and MES2324F DC switches can be used in service provider networks as aggregation or transport switches. They ensure high performance due to the interfaces operating at speeds of 10 Gbps or 1 Gbps.

The switches support physical stacking, VLANs, multicast groups and advanced security functions.



MES2308



MES2324



MES2348B

## Technical features

	MES2308 <sup>CE</sup>	MES2308R <sup>CE</sup>	MES2324 <sup>CE</sup>	MES2324B	MES2324F <sup>CE</sup>	MES2324FB <sup>CE</sup>	MES2348B
<b>Interfaces</b>							
10/100/1000BASE-T (RJ-45)	10	8	24	24	—	—	48
1000BASE-X/100BASE-FX (SFP)	—	—	—	—	20	20	—
1000BASE-X (SFP)	2	—	—	—	—	—	—
10/100/1000BASE-T/1000BASE-X/100BASE-FX Combo	—	2	—	—	4	4	—
10GBASE-R (SFP+)/1000BASE-X (SFP)	—	—	4	4	4	4	4
Console port RS-232 (RJ-45)				1			
<b>Performance</b>							
Bandwidth	24 Gbps	20 Gbps	128 Gbps	128 Gbps	128 Gbps	128 Gbps	176 Gbps
Throughput for 64 bytes <sup>1</sup>	17.7 MPPS	14.7 MPPS	92.1 MPPS	92.1 MPPS	92.1 MPPS	92.1 MPPS	130.9 MPPS
Buffer memory	1.5 MB	1.5 MB	1.5 MB	1.5 MB	1.5 MB	1.5 MB	3 MB
RAM (DDR3)	512 MB						
ROM (RAW NAND)	512 MB						
MAC table	16384						
ARP table <sup>2</sup>	820						
VLAN table	4094						
L2 Multicast groups	2047						

<sup>1</sup> Values are given for 1-way transmission

<sup>2</sup> For each host in the ARP table, an entry is created in the routing table

<sup>CE</sup> — the device complies with CE requirements

## Technical features (continued)

	MES2308	MES2308R	MES2324	MES2324B	MES2324F	MES2324FB	MES2348B
SQinQ rules	958 (ingress/egress)						
ACL rules	958						
L3 IPv4 Unicast <sup>1</sup>	818						
L3 IPv6 Unicast <sup>1</sup>	210						
L3 IPv4 Multicast (IGMP Proxy, PIM) <sup>1</sup>	412						
L3 IPv6 Multicast (IGMP Proxy, PIM) <sup>1</sup>	103						
VRRP switches	255						
Maximum size of ECMP groups	8						
VRF	16 (including default VRF)						
L3 interfaces	130						
Link Aggregation Groups (LAG)	48, up to 8 ports per LAG						
Quality of Service (QoS)	8 egress queues per port						
Jumbo frames	10240 bytes						
Stacking	8 devices						

## Features and capabilities

### Interface functions

- Head-of-line blocking (HOL) protection
- Back pressure
- Auto MDI/MDIX
- Jumbo frames
- Flow control (IEEE 802.3X)
- Port mirroring (SPAN, RSPAN)
- Stacking

### MAC table functions

- Independent learning mode per VLAN
- MAC Multicast Support
- Configurable aging time of MAC addresses
- Static MAC Entries
- MAC Flapping logging

### VLAN functions

- Voice VLAN
- 802.1Q
- Q-in-Q
- Selective Q-in-Q
- GVRP

### L2 Multicast functions

- Multicast profiles
- Static Multicast groups
- IGMP Snooping v1,2,3
- Port/host-based IGMP Snooping Fast Leave
- Pim-Snooping
- IGMP proxy-report
- IGMP authorization via RADIUS
- MLD Snooping v1,2
- IGMP Querier
- MVR

### L2 functions

- STP (Spanning Tree Protocol, IEEE 802.1d)
- RSTP (Rapid Spanning Tree protocol, IEEE 802.1w)
- MSTP (Multiple Spanning Tree, IEEE 802.1s)
- STP Multiprocess
- PVSTP+
- RPVSTP+
- Spanning Tree Fast Link option
- STP Root Guard
- STP Loop Guard
- BPDU Filtering
- STP BPDU Guard
- VLAN-based Loopback Detection (LBD)
- ERPS (G.8032v2)
- Flex-link
- Private VLAN, Private VLAN Trunk
- Layer 2 Protocol Tunneling (L2PT)

### L3 functions

- Static IP routes
- Dynamic routing protocols RIPv2, OSPFv2, OSPFv3, IS-IS (IPv4 Unicast), BGP<sup>2</sup> (IPv4 Unicast, IPv4 Multicast, IPv6 Unicast)
- BFD (for BGP)
- Address Resolution Protocol (ARP)
- Proxy ARP
- Policy-Based Routing (IPv4)
- VRRP
- PIM SM, PIM DM, IGMP Proxy, MSDP
- IP Unnumbered
- ECMP Load Balancing
- VRF

<sup>1</sup> IPv4/IPv6 Unicast/Multicast routes share hardware resources

<sup>2</sup> BGP protocol support is provided under license

## Features and capabilities (continued)

### Link Aggregation functions

- Static LAG
- Dynamic LAG (LACP)
- LAG Balancing Algorithm
- Multi-Switch Link Aggregation Group (MLAG)

### IPv6 functions

- IPv6 Host
- Dual-stack

### Service functions

- Virtual Cable Testing (VCT)
- Optical transceiver diagnostics
- Green Ethernet

### Security functions

- DHCP Snooping
- DHCP Option 82
- IP Source Guard
- Dynamic ARP Inspection
- First Hop Security
- sFlow
- MAC-based authentication, Port Security, Static MAC entries
- Port-based authentication IEEE 802.1x
- Guest VLAN
- DoS attack prevention
- Traffic segmentation
- Protection against non-authorized DHCP servers
- DHCP clients filtering
- BPDU attacks prevention
- NetBIOS/NetBEUI filtering
- PPPoE Intermediate Agent

### ACL (Access Control List)

- L2-L3-L4 ACL
- Time-Based ACL
- IPv6 ACL
- ACL based on:
  - Physical port number
  - IEEE 802.1p
  - VLAN ID
  - EtherType
  - DSCP
  - Protocol type
  - TCP/UDP port number
  - User Defined Bytes

### Quality of Service (QoS) and rate limiting

- QoS statistics
- Shaping, Policing
- IEEE 802.1p Class of Service (CoS)
- Storm Control for different types of traffic (broadcast, multicast, unknown unicast)
- Bandwidth management
- Scheduling algorithms: Strict Priority/Weighted Round Robin (WRR)
- Three marking colors
- ACL-based CoS/DSCP mark assignment
- Setting the IEEE 802.1p priority for management VLAN
- DSCP to CoS/CoS to DSCP remarking
- ACL-based VLAN assignment
- 802.1p, DSCP mark assignment for IGMP

### OAM/CFM

- 802.3ah Ethernet Link OAM
- Dying Gasp
- 802.1ag Connectivity Fault Management (CFM)
- 802.3ah Unidirectional Link Detection (UDLD)

### Management functions

- Download and upload of configuration file via TFTP/SCP
- Redirecting the output of CLI commands to an arbitrary file on ROM
- SNMP
- Command Line Interface (CLI)
- Web interface
- Syslog
- SNTP (Simple Network Time Protocol)
- Traceroute
- LLDP (802.1ab) + LLDP MED
- Processing traffic management with two 802.1Q headers
- Authorization of entered commands using TACACS+ server
- Access control – privilege levels
- Management interface blocking
- Local authentication
- IP addresses filtering for SNMP
- RADIUS, TACACS+ (Terminal Access Controller Access Control System) clients
- Change of Authorization (CoA)
- SSH server, Telnet server
- SSH client, Telnet client
- Remote start of commands via SSH
- SSL
- Macrocommands
- CLI commands logging
- System log
- DHCP autoprovision
- DHCP Relay (Option 82)
- DHCP Option 12
- DHCP Relay, DHCPv6 LDRA (Option 18, 37)
- PPPoE Circuit-ID tag
- Debugging commands
- Rate limit of traffic to CPU
- Password encryption
- Password recovery
- Ping (IPv4/IPv6 support)
- DNS server (Resolver)

### Monitoring functions

- Statistics on interfaces
- RMON/SMON
- IP SLA
- CPU utilization monitoring per task and per traffic type
- RAM utilization monitoring
- Temperature monitoring
- TCAM utilization monitoring

## Features and capabilities (continued)

### MIB/IETF

- RFC 1065, 1066, 1155, 1156, 2578 MIB Structure
- RFC 1212 Concise MIB Definitions
- RFC 1213 MIB II
- RFC 1215 MIB Traps Convention
- RFC 1493, 4188 Bridge MIB
- RFC 1157, 2571-2576 SNMP MIB
- RFC 1901-1908, 3418, 3636, 1442, 2578 SNMPv2 MIB
- RFC 1271,1757, 2819 RMON MIB
- RFC 2465 IPv6 MIB
- RFC 2466 ICMPv6 MIB
- RFC 2737 Entity MIB
- RFC 4293 IPv6 SNMP Mgmt Interface MIB
- Private MIB
- RFC 3289 DIFFSERV MIB
- RFC 2021 RMONv2 MIB
- RFC 1398, 1643, 1650, 2358, 2665, 3635 Ether-like MIB
- RFC 2668 802.3 MAU MIB
- RFC 2674, 4363 802.1p MIB
- RFC 2233, 2863 IF MIB
- RFC 2618 RADIUS Authentication Client MIB
- RFC 4022 MIB for TCP
- RFC 4113 MIB for UDP
- RFC 2620 RADIUS Accounting Client MIB
- RFC 2925 Ping & Traceroute MIB
- RFC 768 UDP
- RFC 791 IP
- RFC 792 ICMPv4
- RFC 2463, 4443 ICMPv6
- RFC 4884 Extended ICMP for Multi-Part messages support
- RFC 793 TCP
- RFC 2474, 3260 DS field definition in IPv4 and IPv6 headers
- RFC 1321, 2284, 2865, 3580, 3748 Extensible Authentication Protocol (EAP)
- RFC 2571, RFC2572, RFC2573, RFC2574 SNMP
- RFC 826 ARP
- RFC 854 Telnet
- IEC 61850

## Use case for access switches

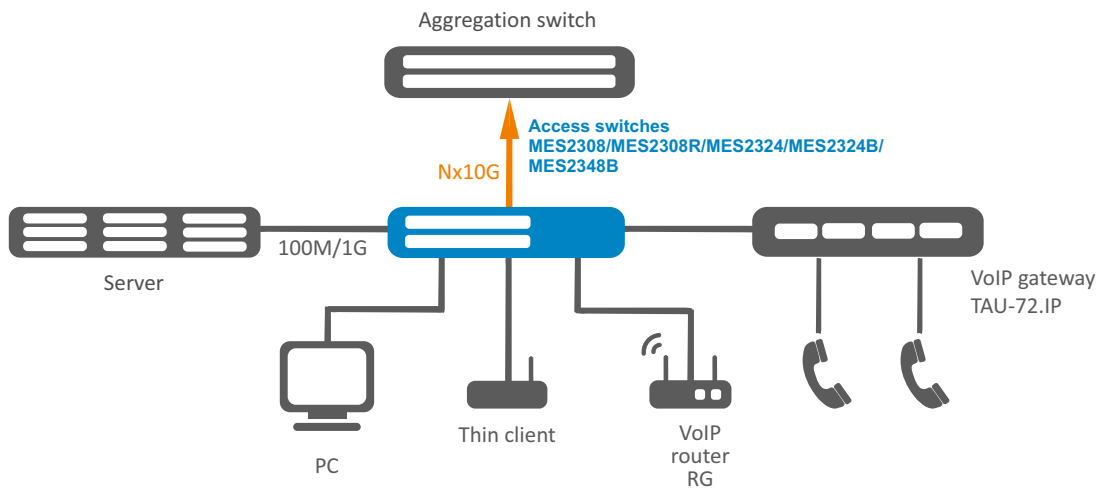

## Use case for aggregation switches

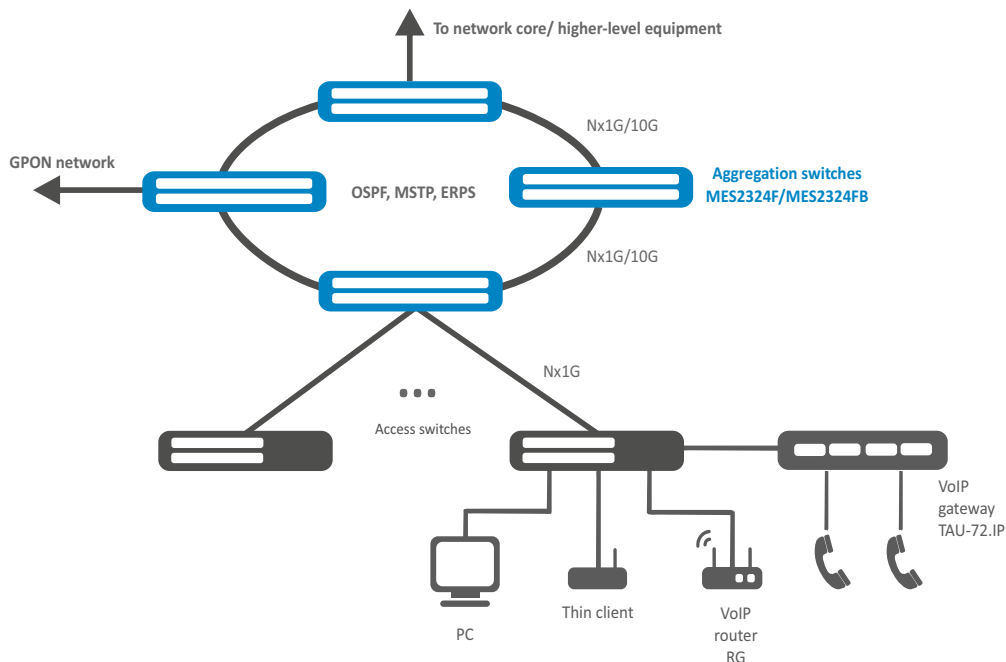

## Physical parameters

	MES2308	MES2308R	MES2324	MES2324B	MES2324F	MES2324FB	MES2348B
<b>Physical specifications and environmental parameters</b>							
Power supply	110–250 V AC, 50–60 Hz	110–250 V AC, 50–60 Hz	110–250 V AC, 50–60 Hz or 36–72 V DC	110–250 V AC, 50–60 Hz; 12 V DC	36–72 V DC	110–250 V AC, 50–60 Hz; 12 V DC	110–250 V AC, 50–60 Hz; 12 V DC
Maximum power consumption	14 W	14 W	25 W	50 W	39 W	85 W	89 W
Maximum power consumption (excluding battery charge)	—	—	—	26 W	—	45 W	45 W
Heat dissipation	14 W	14 W	25 W	28 W	39 W	50 W	54 W
Hardware support for Dying Gasp	no	yes	no	no	no	no	no
Operating temperature	from -20 to +45 °C	from -20 to +50 °C	from -20 to +50 °C <sup>1</sup>	from -20 to +50 °C <sup>1</sup>	from -20 to +65 °C	from -20 to +65 °C	from -20 to +50 °C
Storage temperature	from -50 to +70 °C						
Operating humidity	no more than 80 %						
Cooling	passive	passive	passive	passive	active (4 fans)	active (4 fans)	active (2 fans)
Form factor	19", 1U						
Dimensions (W × H × D)	310 × 44 × 158 mm	310 × 44 × 158 mm	430 × 44 × 158 mm	430 × 44 × 158 mm	430 × 44 × 243 mm	430 × 44 × 243 mm	440 × 44 × 280 mm
Weight	1.45 kg	1.45 kg	2.25 kg	2.25 kg	3.25 kg	3.55 kg	3.85 kg

## Ordering information

Name	Description
<b>MES2308 AC</b>	MES2308 Ethernet switch, 10 ports of 10/100/1000BASE-T, 2 ports of 1000BASE-X, L3, 110–250 V AC
<b>MES2308R AC</b>	MES2308R Ethernet switch, 8 ports of 10/100/1000BASE-T, 2 ports of 10/100/1000BASE-T/1000BASE-X/100BASE-FX Combo, L3, 110–250 V AC
<b>MES2324 AC</b>	MES2324 Ethernet switch, 24 ports of 10/100/1000BASE-T, 4 ports of 10GBASE-R (SFP+)/1000BASE-X (SFP), L3, 110–250 V AC
<b>MES2324 DC</b>	MES2324 Ethernet switch, 24 ports of 10/100/1000BASE-T, 4 ports of 10GBASE-R (SFP+)/1000BASE-X (SFP), L3, 36–72 V DC
<b>MES2324B</b>	MES2324B Ethernet switch, 24 ports of 10/100/1000BASE-T, 4 ports of 10GBASE-R (SFP+)/1000BASE-X (SFP), L3, 110–250 V AC, 12 V DC
<b>MES2324F DC</b>	MES2324F Ethernet switch, 20 ports of 1000BASE-X/100BASE-FX (SFP), 4 ports of 10/100/1000BASE-T/1000BASE-X/100BASE-FX Combo, 4 ports of 10GBASE-R (SFP+)/1000BASE-X (SFP), L3, 36–72 V DC
<b>MES2324FB</b>	MES2324FB Ethernet switch, 20 ports of 1000BASE-X/100BASE-FX (SFP), 4 ports of 10/100/1000BASE-T/1000BASE-X/100BASE-FX Combo, 4 ports of 10GBASE-R (SFP+)/1000BASE-X (SFP), L3, 110–250 V AC, 12 V DC
<b>MES2348B</b>	MES2348 Ethernet switch, 48 ports of 10/100/1000BASE-T, 4 ports of 10GBASE-R (SFP+)/1000BASE-X (SFP), L3, 110–250 V AC, 12 V DC

## Related software

<b>ECCM-MES2308_AC</b>	ECCM-MES2308_AC option of Eltex ECCM control system to manage and monitor Eltex network elements: 1 network element MES2308 AC
<b>ECCM-MES2308R</b>	ECCM-MES2308R option of Eltex ECCM control system to manage and monitor Eltex network elements: 1 network element MES2308R

<sup>1</sup> When using at 45 °C and above, industrial SFP+ transceivers are required.

## Ordering information (continued)

Related software	
<b>ECCM-MES2324_AC</b>	ECCM-MES2324_AC option of Eltex ECCM control system to manage and monitor Eltex network elements: 1 network element MES2324 AC
<b>ECCM-MES2324_DC</b>	ECCM-MES2324_DC option of Eltex ECCM control system to manage and monitor Eltex network elements: 1 network element MES2324 DC
<b>ECCM-MES2324B_AC</b>	ECCM-MES2324B_AC option of Eltex ECCM control system to manage and monitor Eltex network elements: 1 network element MES2324B AC
<b>ECCM-MES2324F_DC</b>	ECCM-MES2324F_DC option of Eltex ECCM control system to manage and monitor Eltex network elements: 1 network element MES2324F DC
<b>ECCM-MES2324FB_AC</b>	ECCM-MES2324FB_AC option of Eltex ECCM control system to manage and monitor Eltex network elements: 1 network element MES2324FB AC
<b>ECCM-MES2348B_AC</b>	ECCM-MES2348B_AC option of Eltex ECCM control system to manage and monitor Eltex network elements: 1 network element MES2348B AC

### Contact us

### About ELTEX



+7 (383) 274 10 01  
+7 (383) 274 48 48



eltex@eltex-co.ru



www.eltex-co.com

**ELTEX Enterprise** is a leading Russian developer and manufacturer of communication equipment with 30 years of history. Complete solutions and their seamless integrability into the Customer's infrastructure are the priority growth areas of the company.